

THE FUTURE OF EMERGENCY LIGHTING



LED EMERGENCY BATTEN

- LiFePO₄WER technology is a sustainable energy development that offers twice the battery life, twice the maintenance-free period and is an environmentally friendly, advancement in sustainability, containing no carcinogens or toxic heavy metals
- High performance Osram LED light source with guaranteed reliability and efficacy
- Optional microwave and daylight sensors
- High efficiency Meanwell power supply
- Smart communications port for M+H Sentinel and M+H Wi Net compatibility
- Maintained / Non-Maintained emergency mode of operation with internal switch link to permit connection of an external switch. For twin tube models, both tubes illuminate on emergency
- Innovative energy efficient LED-driving technology for low standby power consumption and high illumination
- Unique tube-like design with shatter-proof polycarbonate light diffuser
- Prismatic diffusers or wire guards available separately
- Fully tested and approved in accordance to AS / NZS 2293
- 4 hour option available

WHAT IS LiFePO₄WER?

- Li (Lithium) Fe (Iron) PO₄ (Phosphate)
- A long-life, reliable and environmentally friendly energy innovation
- 10 year design life
- Truly sustainable - no carcinogens or toxic heavy metals
- 4 year warranty*

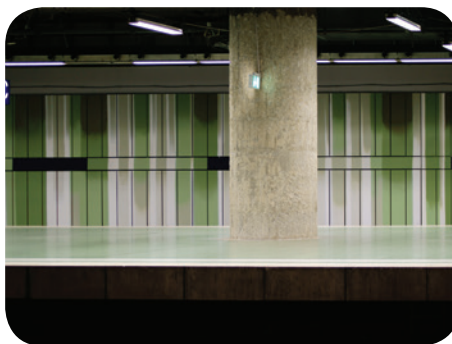

APPLICATIONS INCLUDE

- Carparks
- Stairwells
- Factories
- Apartments
- Warehouses
- Commercial Properties

*LightSaver comes with a 2 year product warranty. To extend the battery warranty to 4 years, simply register. Visit: emergencylighting.mpower.com.au/LightSaverguarantee

Compatible with



M+H WINET™
Centrally Monitored System



M+H SENTINEL™
Automatic Self Testing Unit

Specifications

PART NUMBER	LB12LS	LB22LS	LB14LS	LB24LS	LB12LSWP	LB22LSWP	LB14LSWP	LB24LSWP
POWER CONSUMPTION (STANDBY*)	3W	6W	6W	12W	3W	6W	6W	12W
POWER CONSUMPTION (LEDs)	9.6W	19.2W	19.2W	38.4W	9.6W	19.2W	19.2W	38.4W
OPERATING VOLTAGE & FREQUENCY	240V AC 50Hz							
LIGHT SOURCE	High Performance Osram Duris LEDs							
FUNCTION	Maintained / Non-Maintained with internal switch link to permit external switching							
BATTERY / CHARGER	High Temp Lithium Iron Phosphate with LiFePO ₄ WER™ Technology and intelligent 3-Stage charger							
PROTECTION	Battery: Thermal cut-off, overcharge and low voltage disconnect. Circuit: Overvoltage and overcurrent							
EMERGENCY DURATION	> 2 Hours. 4 hour option available upon request							
INDICATORS / CONTROLS	Charge indicator red LED / Sentinel yellow LED / TEST button							
IP CLASSIFICATION	IP20				IP66			
ENVIRONMENT	Indoor				Outdoor			
BODY CONSTRUCTION	Full anodised aluminium, powdercoated white				Fibre Glass Reinforced Polyester			
DIFFUSER CONSTRUCTION	Acrylic - Prismatic				Polycarbonate			
TEMPERATURE RANGE	0 to 40°C							
STANDARDS	AS / NZS 2293, AS 60598.2.22, EMC to CISPR 15							
M+H WI NET COMPATIBLE	Yes							
M+H SENTINEL COMPATIBLE	Yes							

* Standby Power Consumption based on LED Batten fitted with optional Microwave Sensor being on full standby mode, with batteries fully charged.

ACCESSORIES

D20	600mm Prismatic Diffuser
901875	600mm Wire Guard
D40	1200mm Prismatic Diffuser
901876	1200mm Wire Guard

REPLACEMENT BATTERIES

LIP/4S1P/1500	Replacement battery for LB12LS, LB12LSWP
LIP/4S1P/3200	Replacement battery for LB22LS, LB22LSWP, LB14LS, LB14LSWP
LIP/4S2P/3200	Replacement battery for LB24LS, LB24LSWP

DIMENSIONS

Standard 600mm (2ft)		Standard 1200mm (4ft)		Weatherproof 600mm (2ft)		Weatherproof 1200mm (4ft)	
WEIGHT	3.5kg	WEIGHT	4.5kg	WEIGHT	5.0kg	WEIGHT	5.5kg
LENGTH	620mm	LENGTH	1225mm	LENGTH	667mm	LENGTH	1267mm
WIDTH	125mm	WIDTH	125mm	WIDTH	162mm	WIDTH	162mm
DEPTH	65mm	DEPTH	65mm	DEPTH	100mm	DEPTH	100mm

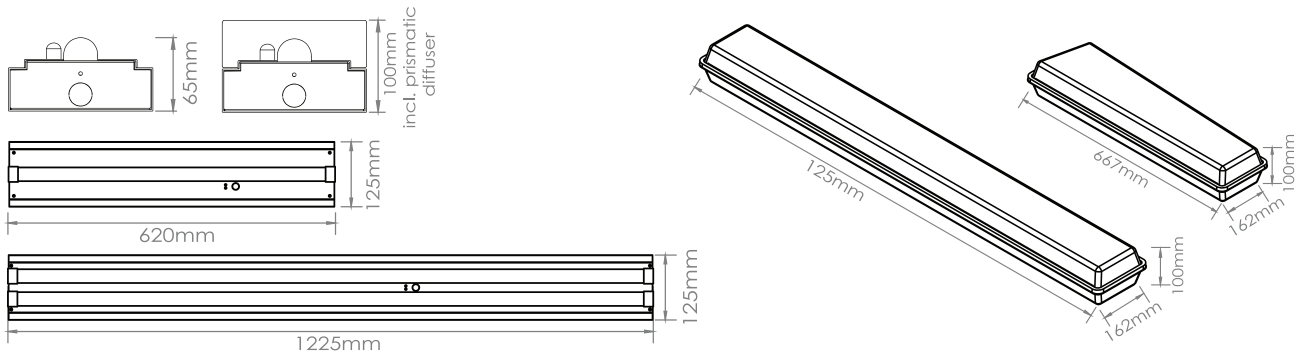

Dimensions and specifications subject to change without prior notice due to ongoing product development policy and changes to industry standards.

SPACING TABLE			MOUNTING HEIGHTS												
PRODUCT	NATA CLASSIFICATION		2.1m	2.4m	2.7m	3m	3.3m	3.6m	4m	5m	6m	7m	8m	10m	15m
LB12LS	C0	D125	24.5	25.6	27.5	28.3	29.1	30.1	31.2	34.0	35.5	36.7	37.8	40.8	40.0
	C90	D63	19.4	20.3	21.1	21.8	22.4	23.0	23.7	25.2	26.4	27.4	28.1	28.9	28.0
LB22LS	C0	D250	30.8	32.2	33.5	34.7	35.8	36.8	38.1	40.9	43.3	45.4	47.2	50.3	55.2
	C90	D125	24.5	25.6	27.5	28.3	29.1	30.1	31.2	34.0	35.5	36.7	37.8	40.8	40.0
LB14LS	C0	D200	28.6	29.9	31.1	32.2	33.2	34.2	35.3	37.9	40.1	42.0	43.6	46.3	50.4
	C90	D100	22.7	23.7	24.6	25.5	26.3	27.0	27.9	29.8	31.4	32.7	33.7	35.3	36.5
LB24LS	C0	D400	36.0	37.6	39.2	40.6	41.9	43.1	44.6	48.0	50.9	53.5	55.7	59.5	66.4
	C90	D200	28.6	29.9	31.1	32.2	33.2	34.2	35.3	37.9	40.1	42.0	43.6	46.3	50.4
LB12LSWP	C0	D40	16.7	17.4	18.0	18.6	19.1	19.6	20.1	21.3	22.1	22.7	23.0	23.1	19.4
	C90	D20	13.1	13.6	14.4	14.5	14.8	15.1	15.5	16.1	16.4	16.3	16.0	14.5	
LB22LSWP	C0	D80	21.1	22.0	22.8	23.6	24.3	25.0	25.8	27.5	28.9	30.0	30.9	32.1	32.4
	C90	D40	16.7	17.4	18.0	18.6	19.1	19.6	20.1	21.3	22.1	22.7	23.0	23.1	19.4
LB14LSWP	C0	D63	19.4	20.3	21.1	21.8	22.4	23.0	23.7	25.2	26.4	27.4	28.1	28.9	28.0
	C90	D32	15.4	16.1	16.7	17.2	17.6	18.0	18.5	19.5	20.2	20.6	20.7	20.3	14.6
LB24LSWP	C0	D125	24.5	25.6	27.5	28.3	29.1	30.1	31.2	34.0	35.5	36.7	37.8	40.8	40.0
	C90	D63	19.4	20.3	21.1	21.8	22.4	23.0	23.7	25.2	26.4	27.4	28.1	28.9	28.0

Energy Saving Technologies

Intelligent microwave sensor with light dimmer control

When coupled with it, this next-generation LED luminaire is able to measure natural daylight, occupancy and activity levels to allow for more efficient light delivery and potentially up to 89% energy savings. It allows the light to turn on automatically when a person's presence is detected, and automatically turns off or drops down to 0 - 50% brightness if no motion is detected after a period of time.

Perfectly Homogeneous Osram Duris LEDs

A new low-power, long life LED that offers a small lumen package, a high efficacy, immensely efficient, and a wide beam angle in a compact format. That is why they are the preferred choice for replacing fluorescent tubes in the field of industry, home, shop, office and signage.

Advanced 3 stage charger for next generation Lithium Batteries

Lithium Iron Phosphate technology contains no toxic heavy metals or carcinogenic materials and is significantly more sustainable, beneficial and effective than existing alternatives such as Nickel Cadmium and Nickel Metal Hydride. The integrated charger system negates the need to constantly charge the batteries when they are at full capacity, ensuring efficient use of energy and reduces waste.

CASE STUDY: Cost Recovery Analysis for 100 x Twin 1200mm 4ft W/P Battens

SAVINGS SUMMARY AT A GLANCE

UP TO 89% ENERGY SAVINGS

TOTAL COST OVER 5 YEARS
LED BATTEN: \$42,585
T8 BATTEN: \$159,492
T5 BATTEN: \$136,716

UP TO \$116,901 SAVINGS OVER 5 YEARS

UP TO 61.6 TONNES LESS CO₂ PER YEAR

PAYBACK PERIOD 0.9 YEARS

	Twin LED Tube 4ft W/P Batten	Twin 36W T8 Tube 4ft W/P Batten (with wound ballast)	Twin 28W T5 Tube 4ft W/P Batten (with electronic ballast)
Initial Supply Cost	\$30,000.00	\$19,000.00	\$23,000.00
CO ₂ created per year (kg)	7,708.8	69,379.2	53,961.6
Total Power Consumption per year (kW/h)	8,760	78,840	61,320
Replacement Tubes	-	\$2,000.00	\$3,200.00
Labour for Replacing tubes	-	\$3,250.00	\$3,250.00
Total Running Cost per year	\$2,277.60	\$20,498.40	\$15,943.20
Total Running Cost over 5 years	\$42,585.18	\$159,492.00	\$136,716.00
Extra Cost of Ownership over 5 Years	-	\$116,906.82	\$94,130.82

All battens are ON 24 hours a day, all LED Battens are fitted with Microwave Sensors and remains in standby mode 90% per day

Return on Investment Graph

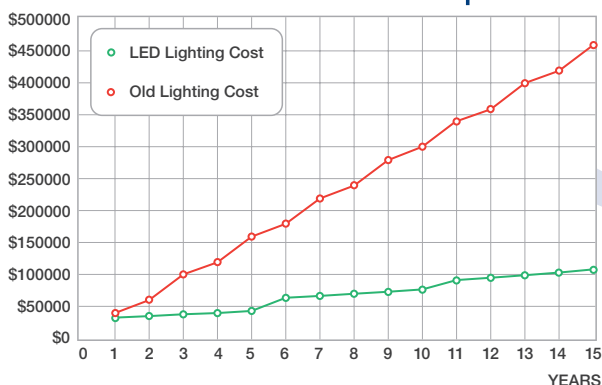

Assumptions

- Based on electricity rate of \$0.26 per kW/h
- Customer buy price - 4ft LED Emergency W/P Batten @ \$300.00 each
 - 4ft T8 Emergency W/P Batten @ \$190.00 each
 - 4ft T5 Emergency W/P Batten @ \$230.00 each
- Power consumption - 4ft LED Emergency W/P Batten @ 10W per fitting (standby)
 - 4ft T8 Emergency W/P Batten @ 90W per fitting
 - 4ft T5 Emergency W/P Batten @ 70W per fitting
- Cost for T8 tubes at \$5 each, cost of T5 tube at \$8 each
- Lifespan: 50,000 hours, T8 lifespan 20,000 hours, T5 20,000 hours
- Labour rate at \$65 per hour, at 15 minutes per fitting
- For CO₂, the emission intensity used is 880g per kWh

Testing & Monitoring Technologies

All M+HBardic-branded products are compatible with M+H Wi Net and M+H Sentinel technology, offering smart testing and monitoring capabilities by using simple plug-and-play modules as required.



M+H Wi Net™ is a web-based real-time emergency lighting monitoring and control system that offers building owners, maintenance managers or service agents total control over their public safety obligations, and helps manage installation and the maintenance of an emergency lighting system.

The system enables the user to:

- Continuously monitor the system in real-time
- Manage the installation and removal of fittings
- Assign fittings to individual groups
- Maintain reliability and integrity of lights by ensuring tests are performed as per AS / NZS 2293
- Log and print test results
- Manage maintenance activities
- Provide long-term cost savings

30 years of experience in state-of-the-art emergency lighting is at your disposal. The M+H Sentinel Automatic Self Testing System is designed to a world standard, providing smart, easy and inexpensive compliance to the AS2293 Standards.

The benefits of M+H Sentinel include:

- No additional wiring
- No test kits required on switchboards
- Can be installed on existing lighting circuits
- Easily retrofitted into M+HBardic products
- Genuine cost savings
- Automatic and manual control
- Luminaire always responds in an emergency
- Fully compliant with AS / NZS 2293



MPower is the leading provider of innovative and dependable power solutions in Australia, New Zealand and the South Pacific. With a history that extends over 100 years, MPower provides a diverse range of power solutions and products for every purpose.

We deliver a vast range of products and solutions to an equally diverse customer base in the green energy, domestic, commercial, oil & gas, industrial, utilities, defence and mining sectors. Our Solutions encompass power generation, power storage, backup power and power conversion.



Australia

Toll Free
Ph: 1300 733 004
Fax: 1300 733 005
lightsaver@mpower.com.au
www.mpower.com.au

Head Office - VIC

9 Mosrael Place
 ROWVILLE VIC 3178
 Ph: +61 3 9763 0555
 Fax: +61 3 9763 0577

NSW

10 Williamson Road
 INGLEBURN NSW 2565
 Ph: +61 2 8788 4600
 Fax: +61 2 9605 3702

Newcastle - Agent

Ross Simington Agencies
 71 Broadmeadow Road
 BROADMEADOW NSW 2292
 Ph: +61 2 4961 3441
 Fax: +61 2 4962 2543

QLD

182 Kerry Road
 ARCHERFIELD QLD 4108
 Ph: +61 7 3272 7579
 Fax: +61 7 3272 9285

SA

426 Churchill Road
 KILBURN SA 5084
 Ph: +61 8 8260 5011
 Fax: +61 8 8260 3455

WA

Unit 2 / 10 Mordaunt Circuit
 CANNING VALE WA 6155
 Ph: +61 8 6254 2211
 Fax: +61 8 6254 2299

NT - Agent

Powerhouse NT
 Unit 2 / 34 Benison Road
 WINNELLIE NT 0820
 Ph: +61 8 8947 0027
 Fax: +61 8 8947 1126

NEW ZEALAND Auckland

Unit B / 237 Bush Road
 ALBANY
 Ph: +64 9 415 6615
 Fax: +64 9 415 8160

Wellington

7 Ward Street
 LOWER HUTT
 Ph: +64 4 586 6188
 Fax: +64 4 586 6088